

Efficient Switchmode Power Supply Start-Up Circuit

by *James Lei, Applications Engineering Manager*

Introduction

The purpose of this application note is to demonstrate the many advantages of using the Supertex LND150N3 in the start-up circuit for switchmode power supplies.

Commonly used low voltage bipolar, CMOS and BiCMOS switchmode power supply PWM ICs usually operate from supply voltages of up to 18V. When the input power for the switchmode converter is available at voltages higher than the maximum voltage rating of the IC, the voltage has to be reduced with a start-up circuit. A frequent requirement is for operation directly from a rectified 120V or 240V AC line without the use of tap changing switches for the selection of different voltages.

The circuit in Figure 1 shows the Supertex LND150N3 being used to provide the low voltage power supply to be connected to the VCC pin of the Unitrode UC3845N PWM IC. This circuit is capable of providing start-up over an input voltage range of 40VDC to 500VDC.

A simple and often-used approach utilizes a power resistor and a Zener diode as shown in Figure 2. The major difference between the two approaches is that the LND150N3 consumes negligible power after the SMPS has started whereas the resistor will draw power continuously from the input line.

For technical information on various aspects of designing such power supplies, please refer to the Supertex application notes AN-H13 and AN-H21 through AN-H24.

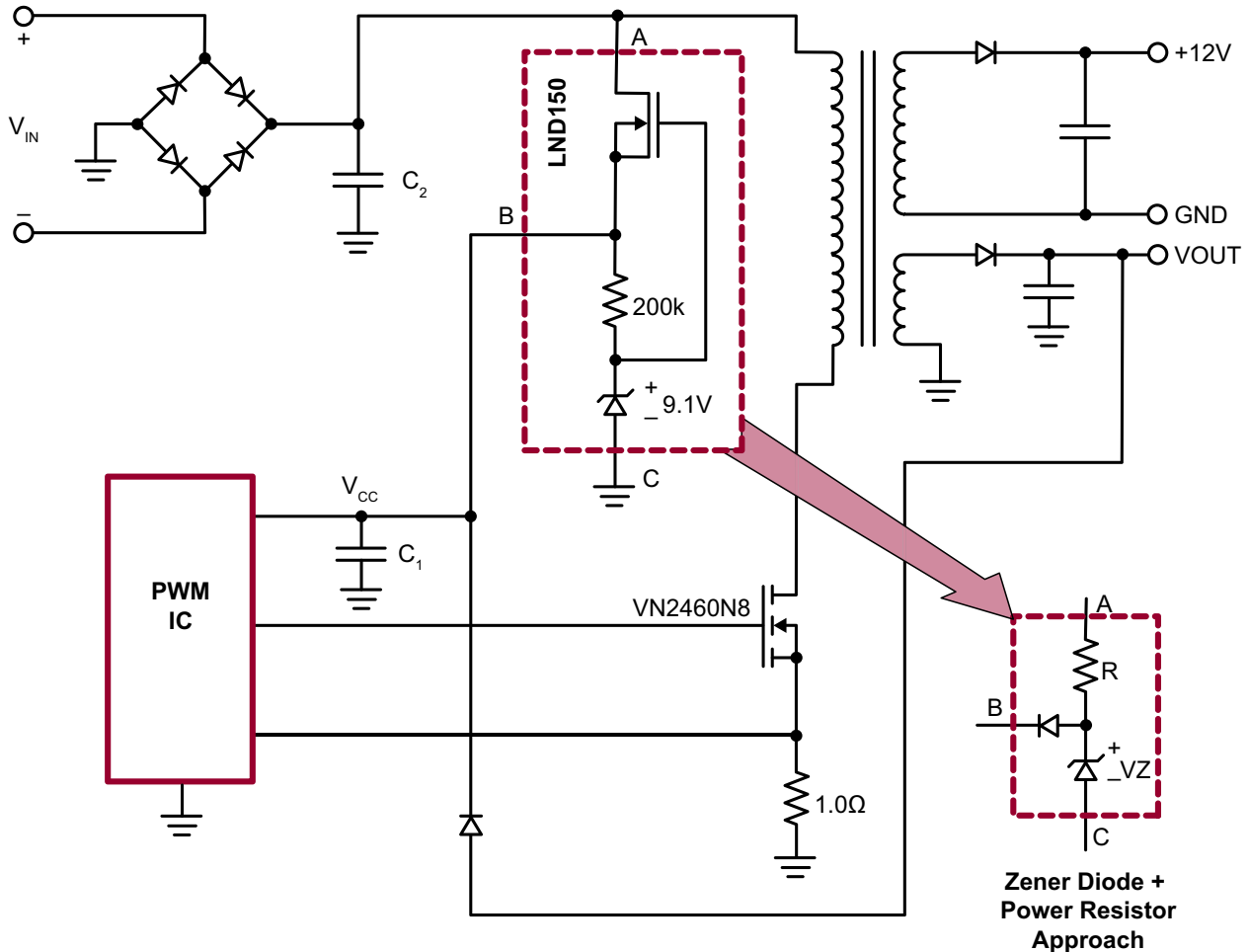

Figure 1: SMPS with LND1 Start-Up

Figure 2: Power Resistor Approach

Power Resistor Approach

Depending on whether the PWM IC utilizes bipolar or CMOS technology, the power rating of the supply and the input voltage available, the continuous power dissipated in the resistor may be up to 5.0 watts or even higher. For example, if the current required is 10mA, from a 240VAC line the power dissipated will be 3.4 watts. The start-up current can be quite high when the power supply uses a large MOSFET switch, since a considerable current is required by the buffers or MOSFET drivers in addition to the I_{DD} or I_{CC} of the PWM IC. This causes 4 major problems:

- a) Excessive heat on the PC board;
- b) Narrow input voltage operating range;
- c) Loss of efficiency;
- d) Large size of power resistor.

These problems can become very difficult to solve, especially in compact, off-line switchmode power supplies used in portable equipment, e.g., laptop and notebook computers, battery chargers, etc.. In such equipment, space is at a premium and management of the generated heat is very troublesome. Reducing the temperature rise on densely populated PC boards may often be impossible, resulting in potentially reduced system reliability. For such applications, designers often face the task of achieving very high efficiency for power supplies, with minimal board space, operating directly from 120VAC, 240VAC, or other international utility voltages.

The Unitrode part #UC3845N specifications relevant to the start-up are as follows:

<i>Start-up current</i>	<i>1.0mA max</i>
<i>Operating current</i>	<i>17.0mA max</i>
<i>Start-threshold voltage</i>	<i>9.0V max</i>
<i>Min. operating voltage after turn-on</i>	<i>8.2Vmax</i>

The start-up current is the biasing current for the IC when the output is not switching. Once the output starts switching, the IC is considered to be in the operating mode and will draw no more than 17.0mA plus the load current being sourced into the gate of the MOSFET. This load current is calculated as f_{CV} , where f is the operating frequency, C is the effective input capacitance, and V is the V_{CC} voltage. The value for the resistor, R, must be small enough such that under the worst case condition of minimum input line voltage, it can source 1.0mA to the IC and some biasing current for the Zener diode, I_{BIAS} . The value of R is calculated as follows:

$$R = \frac{V_{IN(MIN)}}{(1.0mA + I_{BIAS})}$$

The worst case power dissipation is determined as follows:

$$P_{DISS} = \frac{(V_{IN(MAX)})^2}{R}$$

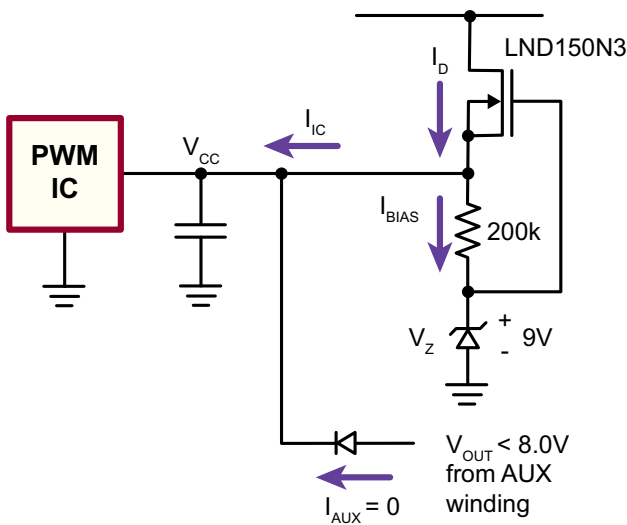

Figure 3a: Current Paths During Start-Up

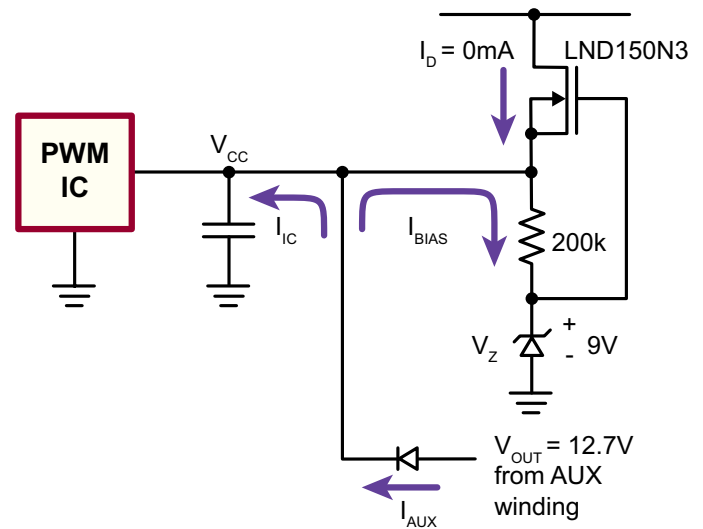

Figure 3b: Current Paths After Start-Up

The continuous power dissipation at higher voltages from R increases when the required input operating voltage for the converter is widened. Consider for example a converter required to operate at 120VAC and 240VAC. R is calculated as:

$$R = \frac{(120) \cdot (1.414) \cdot V}{(1.0mA + 100\mu A)}$$

$$R = 154K\Omega$$

Operating the power supply from rectified 240VAC, R will dissipate:

$$P = \frac{(240 \cdot 1.414)^2}{154K\Omega}$$

$$P = 0.75 \text{ watts}$$

LND150 Circuit Description

The start-up circuit portion of Figure 1 is analyzed and shown with additional notes in Figures 3a and 3b. Figure 3a shows the current paths during start-up and Figure 3b is after the start-up has occurred. The following main specifications of the LND150N3 are considered:

Parameter	Min	Max
Drain-to-source breakdown voltage - BV_{DSS}	500V	-
Gate-to-Source off voltage - $V_{GS(OFF)}$	-1.0V	-3.0V
Saturated drain-to-source current - I_{DSS}	1.0mA	3.0mA

LND150N3, the TO-92 version of LND1E, is configured as a source follower. Being a depletion-mode MOSFET, the

LND1E is always in the “ON” state when there is 0V gate-to-source bias. When power is available at the input of the power supply, the LND150N3 supplies current to charge up capacitor C and biases the 9V Zener diode through the external 200KΩ source resistor as shown in Figure 4a. The $V_{GS(OFF)}$ of the LND150N3 divided by this resistor approximates the biasing current for the Zener diode. The V_{CC} generated is approximately equal to:

$$V_{CC} = (V_Z - V_{GS(OFF)}) (1 - \sqrt{I_{DD} / I_{DSS}})$$

and is almost completely constant within the input voltage range of ($V_Z + 3.0V$) to 500V. The same circuit can therefore be used without any modifications for both 120VAC and 240VAC. A sourcing current equal to the I_{DSS} of the device will cause V_{CC} to be equal to V_Z . The amount of source current will range from 1.0mA to 3.0mA per guaranteed minimum and maximum values of I_{DSS} in the LND150N3 data sheet. The guaranteed 1.0mA minimum specification satisfies the maximum current required for the UC3835N to start up.

Once V_{CC} is generated, it allows the PWM IC to start up and generate a DC voltage V_{OUT} from one of the auxiliary winding. The turns ratio on the transformer should be designed so that:

$$V_{OUT} \geq 3.0V + V_Z + 0.7V$$

This allows the LND150N3 to be turned “OFF” as shown in Figure 3b. By setting $V_{OUT} = 12.7V$, the source of the LND150N3 will be at 12V and the gate will be at 9.0V. The LND150N3 gate-to-source voltage will therefore be 9.0V - 12V = -3.0V, which turns it “OFF”. After the start-up described above, the only current drawn by this circuit from the rectified AC line is the small amount of drain-to-source leakage current, $I_{D(OFF)}$, typically less than 100nA.

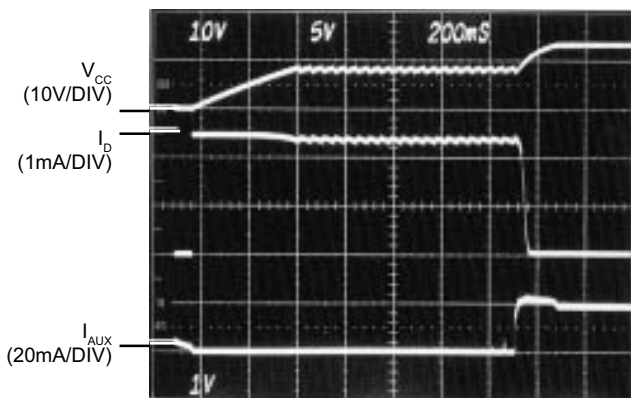

Figure 4: Start-Up Waveforms for V_{CC} , I_D , I_{AUX} at $V_{IN} = 40VDC$

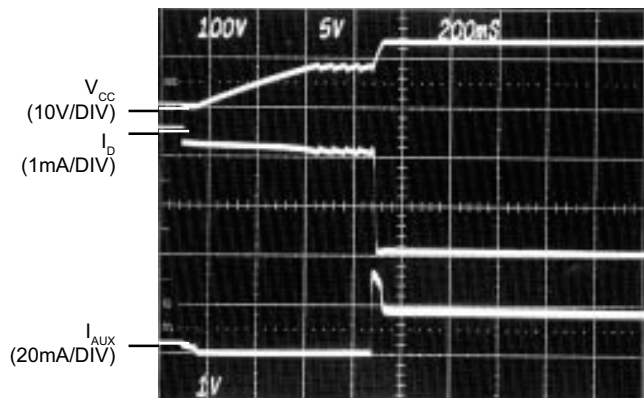

Figure 5: Start-Up Waveforms for V_{CC} , I_D , I_{AUX} at $V_{IN} = 400VDC$

The maximum power dissipation on the LND150N3 is determined by:

$$P_{DISS} = (I_{DSS(MAX)}) \cdot (V_{IN(MAX)})$$

$$P_{DISS} = (3.0mA) \cdot (240V) \cdot (1.414)$$

$$P_{DISS} = 1.02 \text{ watts}$$

The 1.02 watt is only being dissipated for a short duration during start-up. After start-up, it dissipates virtually no power.

Start-up Current Waveforms

To demonstrate the performance of the LND150N3 in the start-up circuit, the 3.0watt power supply shown in Figure 1 was built and tested. V_{IN} was tested with a DC input of 40VDC and a rectified sinusoidal 285VAC, which was obtained from the utility via a step-up transformer. The converter was powered up with its maximum load of 3.0watts connected to the outputs. The V_{CC} voltage, drain current of the LND150N3 (I_D), and the current from the auxiliary winding (I_{AUX}) were simultaneously monitored during the start-up.

Figure 4 shows the voltage and current waveforms with $V_{IN} = 40VDC$. Figure 5 shows voltage and current waveforms of the same circuit under the same conditions except the input voltage is a rectified 285VAC.

You will observe that the performances shown in Figures 4 and 5 are similar except that the latter shows a faster power-up.

The sequence of events before the start-up, as shown in Figure 4, is described as follows. Initially, all voltages are at 0V. When 40VDC is applied to V_{IN} , the LND150N3 starts charging the 100 μ F capacitor C_1 at a rate equal to the LND150N3's I_{DSS} minus the input current drawn by the IC, I_{IC} . The actual value of I_{DSS} for this device is 2.4mA as seen by the waveform I_D . V_{CC} will therefore ramp up at the following rate:

$$\frac{dv}{dt} = \frac{(I_{DSS} - I_{IC})}{C_1}$$

$$= \frac{(2.45 - 0.5)mA}{100\mu F}$$

which is 3.8V/200msec or 3.8V/division. Initially, there is no current from the auxiliary winding because the converter

is not running. Once V_{CC} reaches the UC3835N's start-up threshold voltage of 9.0V, the output will start switching the power MOSFET, a Supertex VN2460N8 at a frequency of 40KHz. During the time the IC is driving the external switching MOSFET, it will draw 16mA from C_1 . The IC will continue to operate and drive the MOSFET until V_{CC} discharges to the IC minimum operating voltage after turn-on specification, which is about 8.0V, at which time the under voltage lock-out does not allow operation. During the time the MOSFET is switching, the auxiliary winding supplies current and charges the capacitor C_1 , which builds up its voltage step by step, every time the MOSFET switches. As long as the voltage build-up in steps is below the under voltage lock-out level, i.e., less than 8.0V, the sequence of events above will be repeated.

Once again, the LND150N3 charges C_1 from 8.0 to 9.0V. Once V_{CC} reaches 9.0V, the IC starts switching the VN2460N8 MOSFET and the voltage on the auxiliary winding, V_{OUT} , further increases. The cycle repeats itself several times until the V_{OUT} reaches 9.0V. Once V_{OUT} reaches 9.0V, it will supply the 16mA to the IC so C_1 will no longer discharge to 8.0V. This allows the converter to continue to operate and V_{OUT} to reach 12.7V. At this time, the LND150N3 is turned "OFF", I_D goes to 0mA, V_{CC} ramps up to 13V and I_{AUX} charges C_1 from 9.0 to 13V and settles to 16mA.

The only difference between the waveforms shown in Figures 4 and 5 is that the circuit powers up faster when a higher voltage is applied at the input of the power supply. A rectified 285VAC line gives a 400VDC line which allows the primary of the transformer to have a higher di/dt and consequently induce a large voltage in the secondary auxiliary winding. This causes the capacitor C_1 to charge up faster as compared to the operation at 40V. The peak power dissipation for the LND150N3 is:

$$P = (400V) \cdot (2.4mA) = 0.96Watts$$

for only 240 milliseconds.

Higher Start-up Current

The Supertex DN2540N3 can be used for applications requiring much higher start-up currents because the I_{DSS} minimum of this device is rated at 150mA. This device has a BVDSS rating of 400V minimum and is available in the TO-92, TO-220 and SOT-89 package to suit various commercial and industrial grade applications.

This device can be used by an addition of a current limiting resistor, R_{LIM} as shown in Figure 6. The small current limiting resistor, R_{LIM} , is recommended to develop a slightly negative V_{GS} to set the desired output current and ensure the ID value does not allow the DN2540 power rating to be exceeded.

Conclusion

The start-up circuit using the LND150N3 improves the overall efficiency, reduces power dissipation, widens operating input voltage range, and reduces board space which would be required by a large power resistor. For surface mount requirements, the LND150N8, which is the SOT-89 (TO-243AA) version of the part, allows efficient use of board space.

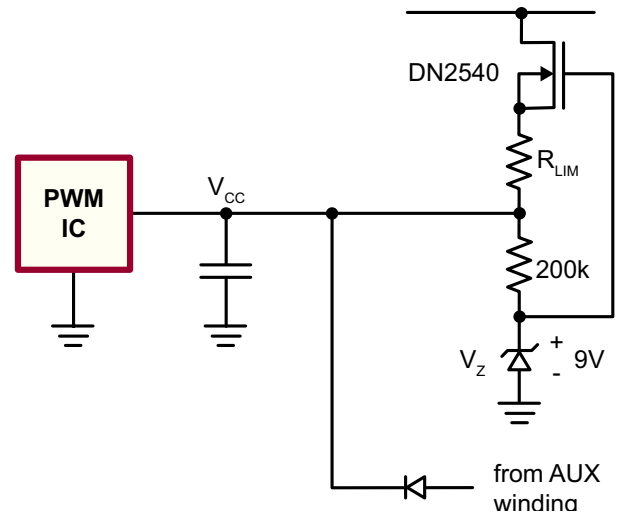

Figure 6: High Current Start-Up

Supertex inc. does not recommend the use of its products in life support applications, and will not knowingly sell them for use in such applications unless it receives an adequate "product liability indemnification insurance agreement." **Supertex inc.** does not assume responsibility for use of devices described, and limits its liability to the replacement of the devices determined defective due to workmanship. No responsibility is assumed for possible omissions and inaccuracies. Circuitry and specifications are subject to change without notice. For the latest product specifications refer to the **Supertex inc.** (website: <http://www.supertex.com>)